

AMERICAN CABLE ROLL-OFF HOISTS

Distributed by Marrel Corp.

Optimized design with the widest range
of capacities.

LIFETIME EXCELLENCE



AMERICAN CABLE ROLL-OFF HOIST
DISTRIBUTED BY MARREL CORP.
4750 14 Mile Rd NE | Rockford | MI 49341

T + 1 866 822 3580
F + 1 616 863 9177

FIRST CLASS IN DESIGN & PERFORMANCE

Each day brings new challenges.

However varied and diverse your daily applications may be - whether wood, concrete or steel - they all have one thing in common: **A STRONG PARTNER.**

Your obstacles out in the field matter and that's why we put so much passion into our equipment - to make you more successful. Our machines are more than just technology... they are the result of your experiences and our innovations – worldwide. Our products are solutions that we develop *with you.*



THE AMERICAN CABLE ROLL-OFF - ARH HEAVY DUTY SERIES

Handle the heaviest of loads with our Heavy Duty Cable Roll-off Hoists. Extremely versatile, all of our Heavy Duty models can handle up to 75,000 lbs. – making them the perfect fit for your heavyweight jobs in tough industries like scrap and other heavy duty sectors.

MODEL	CAPACITY (LB.)	CONTAINER LENGTH (FT.)	DUMP ANGLE	MIN C/T (IN.)	HOIST LENGTH (IN.)	GVWR F/R (LB.)	ET – Extendable Tail IO – Inside / Outside XD – Extreme Duty
ARH 75-22	75000	12-22 ft.	48	176	289	18,000/46,000	
ARH 75-22 IO	75000	12-22 ft.	48	176	289	18,000/46,000	
ARH 75-22 XD	75000	12-22 ft.	48	176	289	18,000/46,000	
ARH 75-24	75000	12-24 ft.	48	194	307	18,000/46,000	
ARH 75-24 IO	75000	12-24 ft.	48	194	307	18,000/46,000	
ARH 75-24 XD	75000	12-24 ft.	48	194	307	18,000/46,000	

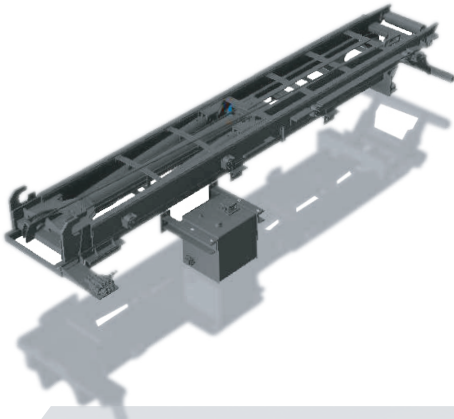

ART - TOP MOUNT SERIES

Designed for a long life with minimal maintenance, our patented Top Mount Cable Roll-off Hoists are unique to the market. The innovative top mount design is suitable for single and multiple axle chassis, making these hoists perfect for mounting on top of any chassis configuration, including CNG tanks.

Plus, our top mount design also offers the most diverse capacity range, from 12,000 - 75,000 lbs.

MODEL	CAPACITY (LB.)	CONTAINER LENGTH (FT.)	DUMP ANGLE	MIN C/A (IN.)	MIN C/T (IN.)	HOIST LENGTH (IN.)	GVWR F/R (LB.)
ART 12-12	12000	10-12 ft.	53	84	-	188	7,000/12,500
ART 12-14	12000	12-14 ft.	48	108	-	217	7,000/12,500
ART 20-16	20000	12-16 ft.	56	120	-	212	7,000/12,500
ART 20-18	20000	12-18 ft.	52	140	-	236	7,000/12,500
ART 30-16	30000	12-16 ft.	56	125	-	222	12,000/21,000
ART 30-16 ET	30000	12-16 ft.	56	125	-	196-222	12,000/21,000
ART 30-22	30000	12-22 ft.	48	176	-	289	12,000/21,000
ART 30-22 ET	30000	12-22 ft.	48	176	-	260-320	12,000/21,000
ART 40-16	40000	12-16 ft.	56	164	118	222	12,000/40,000
ART 40-16 ET	40000	12-16 ft.	56	164	118	196-222	12,000/40,000
ART 40-22	40000	12-22 ft.	48	-	176	289	12,000/40,000
ART 40-22 ET	40000	12-22 ft.	48	-	176	260-320	12,000/40,000
ART 60-22	60000	12-22 ft.	49	-	176	289	18,000/46,000
ART 60-22 ET	60000	12-22 ft.	49	-	176	260-320	18,000/46,000
ART 75-22	75000	12-22 ft.	48	-	176	289	18,000/46,000
ART 75-22 ET	75000	12-22 ft.	48	-	176	260-320	18,000/46,000
ART 75-22 IO	75000	12-22 ft.	48	-	176	289	18,000/46,000
ART 75-24	75000	12-24 ft.	48	-	194	307	18,000/46,000
ART 75-24 ET	75000	12-24 ft.	48	-	194	287-367	18,000/46,000
ART 75-24 IO	75000	12-24 ft.	48	-	194	307	18,000/46,000